

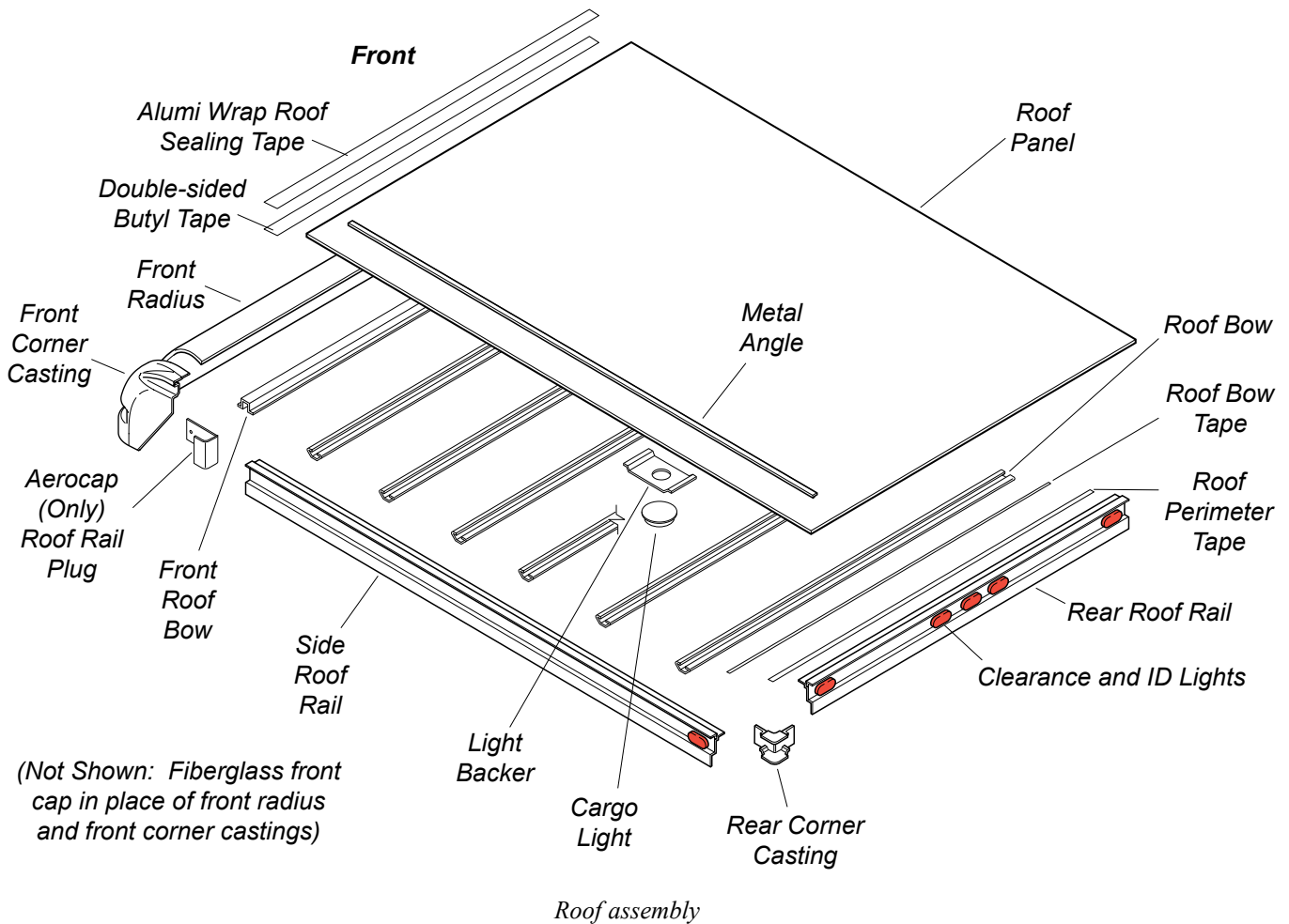

A SPARTAN MOTORS COMPANY

Service Guide

Roof Truck Body and Cutaway



NOTE: This service information is generic. Details in illustrations and procedures may differ from those in your vehicle. Because Utilimaster manufactures many customized vehicle bodies, this manual cannot list and illustrate every possible part in every vehicle. Nevertheless, the most common body options are described here. Use this information as a guideline where it applies.

⚠ CAUTION

Always follow the manufacturer's cautions and recommendations for protective equipment, application, and cleanup.

NOTICE

Removal and replacement of the roof could result in roof leaks. If a vehicle requires major roof or structural repair, check with Utilimaster for a recommendation on returning the vehicle to Utilimaster or repairing damage at a professional body shop.

Some vehicles have a one-piece fiberglass front roof cap. Others have a separate aluminum front radius and two aluminum corner castings.

Front Fiberglass Cap Replacement

Removal

1. Remove all clearance and identification lights for reuse.
2. Remove the roof sealing tape over the front roof cap and roof panel seam.
3. Remove the fasteners holding the front cap to the roof and wall sections.
4. Using a razor knife, cut the sealant and tape around the cap. Pull off the cap.

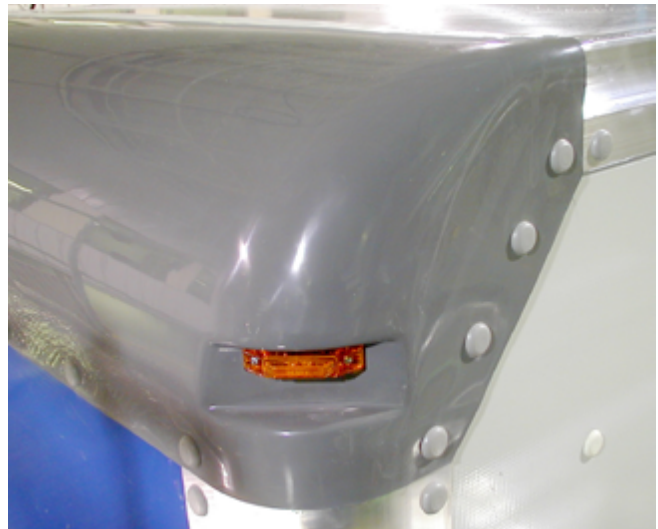

Fiberglass front roof cap

Installation

1. Scrape off old sealant and tape and clean the bonding surfaces with isopropyl alcohol.

NOTICE

For the new cap, drill new holes using the old cap as a model (if possible) or mark and drill hole locations from test-mounting the cap on the vehicle.

2. Place double-sided butyl tape along top edge of the roof panel.
3. Carefully place the cap in position and fasten in place.
4. Apply "Alumi Wrap" roof sealing tape where the front cap and the roof panel overlap.
5. Apply polyurethane sealant around the exterior perimeter of the cap.
6. Install the lights removed from the original cap.
7. After an eight-hour waiting period, water-test the roof. Spray the roof and the top of the side structures near the affected area. Check for leaks. Reseal and retest if any leaks appear.

Front Aluminum Corner Casting Replacement

NOTICE

If the vehicle has a front roof cap, see the Front Fiberglass Cap Replacement section.

Removal

1. Remove the clearance light for reuse.
2. Remove the fasteners holding the casting to the front radius, walls, and roof.
3. Using a utility knife, cut the sealant around the casting. Pull off the casting.

Installation

1. Scrape off the old sealant and clean the bonding surface with isopropyl alcohol.

NOTICE

For the new casting, drill new holes using the old casting as a model (if possible) or mark and drill hole locations from test-mounting the casting.

2. Apply polyurethane sealant along the bonding surface where the casting will mate with the front radius, roof, and walls.
3. Fasten the casting into place.
4. Apply polyurethane sealant around the exterior perimeter of the corner casting.
5. Install the clearance light removed from the original casting.
6. After an eight-hour waiting period, water-test the roof. Spray the roof and the top of the side structures near the affected area. Check for leaks. Reseal and retest if any leaks appear.



Aluminum front corner casting and radius

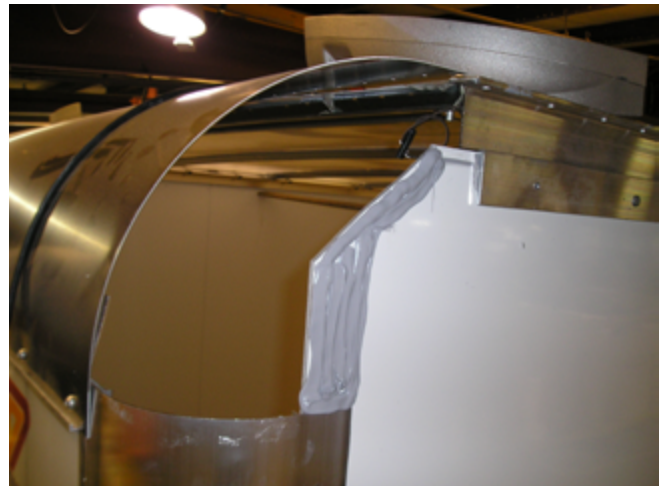

Sealant on bonding surface

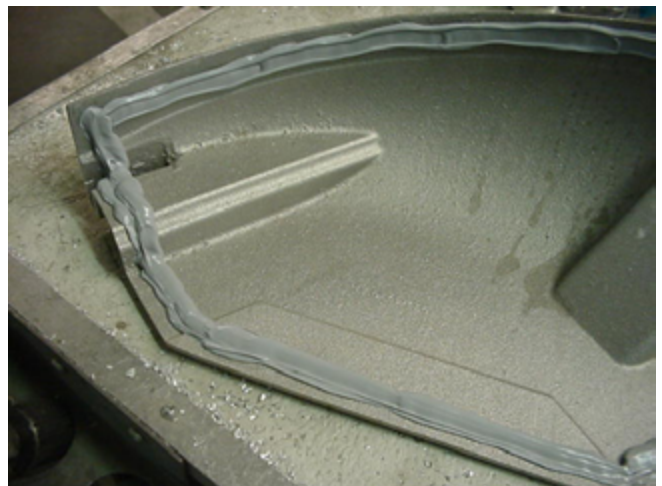

Sealant bead on corner casting

Front Aluminum Radius Replacement

NOTICE

If the vehicle has a front roof cap, see the Front Fiberglass Cap Replacement.

Removal

1. Remove any identification lights on the radius for reuse.
2. Remove the tape over the front radius and roof panel seam.
3. Remove the castings.
4. Remove the fasteners holding the front radius to the corner castings.
5. Using a razor knife, cut the sealant and tape around the radius. Pull off the radius.

Installation

1. Scrape off old sealant and tape and clean the surfaces with isopropyl alcohol.

NOTICE

Drill new holes using the old radius as a model or mark and drill hole locations by test-mounting the radius on the vehicle.

2. Place double-sided butyl tape along top edge of the roof panel.
3. Carefully place the radius in position and fasten in place.
4. Reinstall the corner castings.
5. Apply “Alumi Wrap” roof sealing tape where the front radius and the roof panel overlap.
6. Apply polyurethane sealant around the exterior perimeter of the radius.
7. Install any identification lights removed from the original radius.
8. After an eight-hour waiting period, water-test the roof. Spray the roof and the top of the side structures near the affected area with water. Check for leaks. Reseal and retest if any leaks appear.

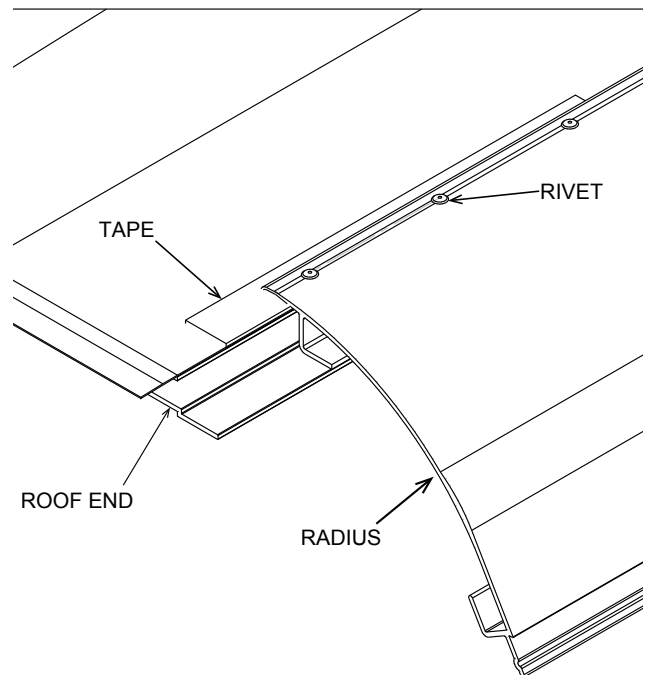

Roof radius

Rear Corner Casting Replacement

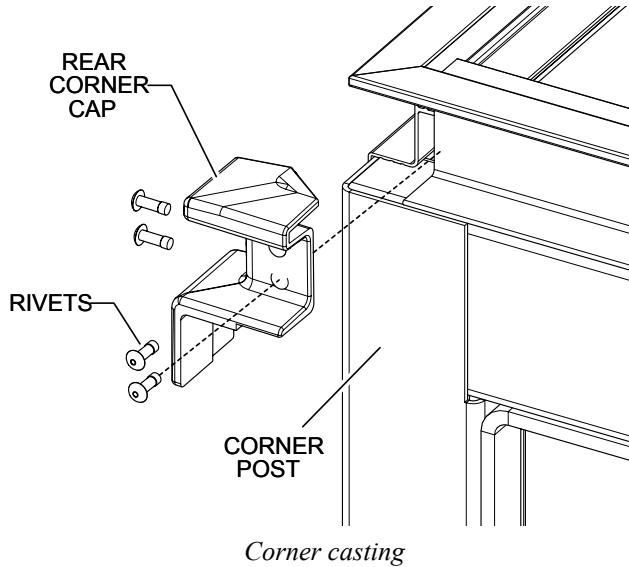

Removal

1. Remove the fasteners holding the casting to the roof rails.
2. Using a utility knife, cut the sealant around the casting.
3. Pull off the casting.

Installation

1. Scrape off the old sealant and clean the bonding surface with isopropyl alcohol.

NOTICE

For the new casting, drill new holes using the old casting as a model (if possible) or mark hole locations from test-mounting the casting.

2. Apply polyurethane sealant along the bonding surface where the casting will mate with the roof rails.
3. Fasten the casting into place.
4. Apply polyurethane sealant around the exterior perimeter of the corner casting.
5. After an eight-hour waiting period, water-test the roof. Spray the roof and the top of the side structures near the affected area with water. Check for leaks. Reseal and retest if any leaks appear.

Roof Panel Repair

Quick and easy translucent fiberglass repair kits are available for permanently repairing small tears and punctures. These kits, such as Kemlite® SunPatch™ repair kit (P/N 01900680), work in a wide range of temperatures and do not require the mixing of resins.

Roof Panel Replacement

NOTICE

If the roof panel is translucent Kemlite®, Utilimaster recommends the use of a patch kit such as SunPatch™ (P/N 01900680) where possible.

A heat gun may help break the adhesive bond holding the translucent panel to the roof bows and rails.

Removal

1. Remove the tape over the front radius and roof panel seam.
2. Remove the fasteners securing the panel to the front radius and roof panel to the roof rails.
3. Remove the metal angle above the rails.
4. Cut the double-sided tape between the roof panel and the front radius, roof bows, and rails with a razor knife.

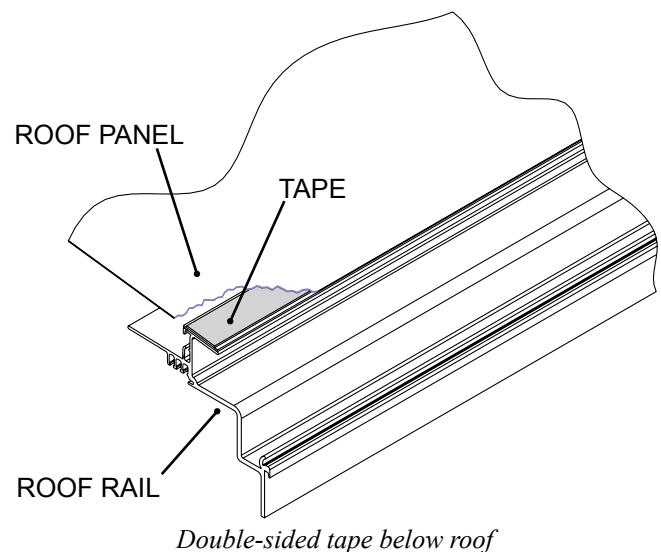

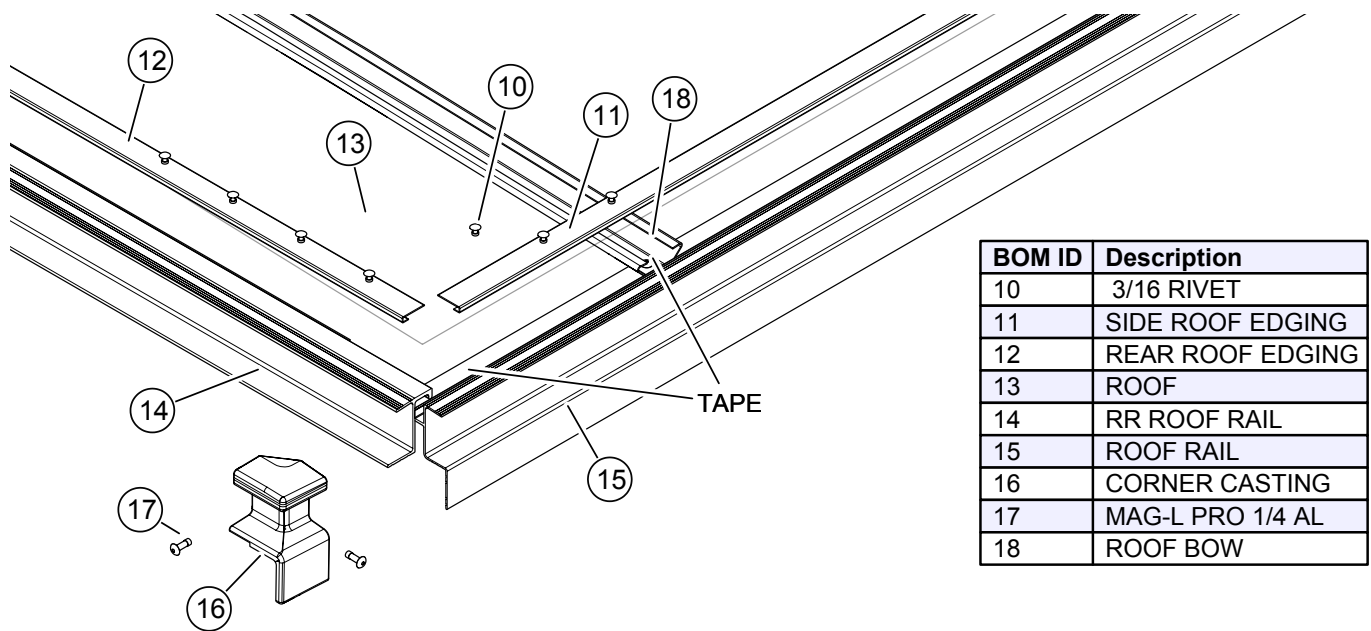

Roof overview

- Remove the panel. Some prying and additional cutting of tape may be required to break the panel loose from the roof bows and rails.
- On the outer edge of the rail mark each rivet location for reference after a new metal angle is placed on top.
- Use a angle grinder to grind down all rivet stems until they are flush with the rail surface. Be careful to not grind off excess metal.
- Scrape the rails, front radius, and roof bows to remove the old tape.
- Clean the tape areas with isopropyl alcohol and allow to dry.

Installation

- Test fit the new panel and trim as required.
- Remove the panel.
- Apply double-sided butyl tape along the bottom of the front radius where the roof panel will overlap. On the side facing down, leave the paper strip on for now.
- Apply 1/2"-wide tape (P/N 12605933) on all the roof bows. On the side facing up, leave the paper strip on for now.

NOTICE

In older trucks that used polyurethane sealant instead of tape along the tops of the roof bows and rails, you may choose to use sealant in those places, but tape is easier and cleaner to install.

- Apply the 1"-wide adhesive tape (P/N 12605927) around the roof perimeter on the side and rear roof rails. On the side facing up, leave the paper strip on for now.
- Peel off about an inch (a few centimeters) of the tape paper at each tape end of the roof perimeter.
- Peel off about an inch (a few centimeters) of the tape paper at each end of the roof bows.
- Lay down the new roof panel.

NOTICE

As you are lowering the panel, make sure you can reach (from the interior or the exterior) the peeled-off paper on every tape strip.

9. Carefully lay down the new roof panel, inserting the front edge under (the tape of the) front radius, and then carefully remove the paper strip on the tape (between the radius and the roof).
10. Carefully pull out all the remaining tape paper.
11. Use a roller to apply pressure around the perimeter to firmly adhere the tape to the roof.
12. Place new metal angles over the panel ends and over the rails.
13. Drill 3/16" (for buck rivets) or 1/4" (for Magna-Loks) holes through the new metal angles and panel staggered from the old rivets.
14. Fasten the panel in position with fasteners.
15. Using the holes in the front radius as a template, drill 3/16" holes through the roof panel.
16. Fasten the panel to the front radius with POP rivets.
17. Apply Alumi-Wrap roof sealing tape where the front radius and the roof panel overlap.
18. Apply a bead of sealant around the exterior perimeter of the panel. Ensure there are no voids in the sealant.
19. After an eight-hour waiting period, water-test the roof. Spray the roof and the top of the side structures with water. Check for leaks. Reseal and retest if any leaks appear.

Utilimaster Customer Service

574-848-2200

Email: FVSPartsInfo@SpartanMotors.com

Roof Truck Body and Cutaway Service Guide

January 2018

©Utilimaster, 603 Earthway Boulevard, Bristol, Indiana 46507, USA